

REFERENCE IN-WALL SUBWOOFERS

R10SUB | R12SUB QUICKSTART GUIDE



Box Contents

- (1) Quickstart Guide
- (1) Reference NC driver (R10SUB or R12SUB)
- (1) Grille mounting frame
- (1) Grille
- (12) M3.5 * 25mm Flat Head Phillips Wood Screws for mounting the frame
- (12) M3.5 * 45mm Flat Head Phillips Wood Screws for mounting the frame
- (12) M5 * 18mm Phillips Machine Screws for mounting the driver

NOTE: R10SUB AND R12SUB REQUIRE USE OF SONANCE R10SUB ENC AND R12SUB ENC, RESPECTIVELY.

Installing the Driver after Drywall and Paint

1. Remove the four screws that attach the cover plate to the enclosure (see Figure 1).

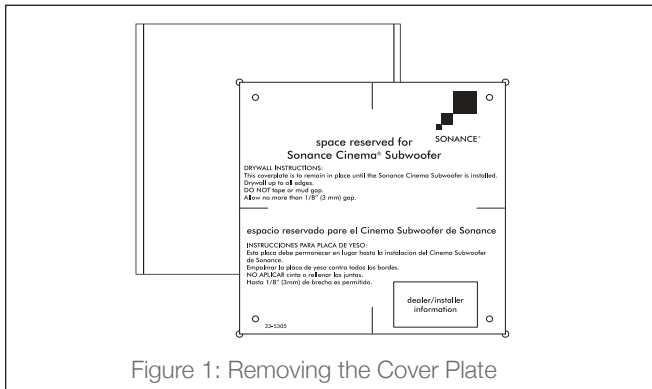

Figure 1: Removing the Cover Plate

2. Connect the internal speaker wire to the woofer driver. Connect the RED wire to the positive terminal and the BLACK wire to the negative terminal. If using multiple subwoofers it is critical that the polarity of all the woofers is the same (see Figure 2).

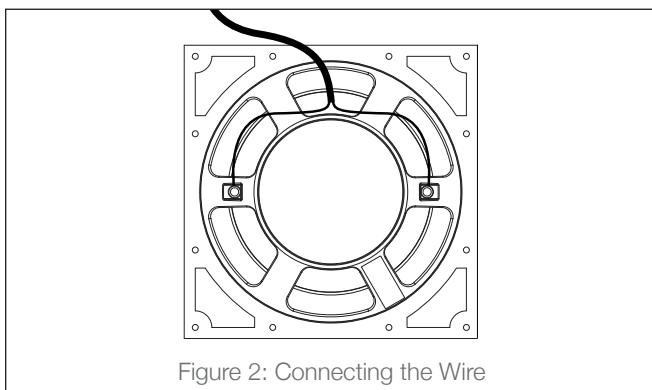

Figure 2: Connecting the Wire

3. Attach the woofer driver to the enclosure using the twelve Phillips head screws.

4. Tighten all twelve screws evenly to minimize any air leakage that could occur (see Figure 3).

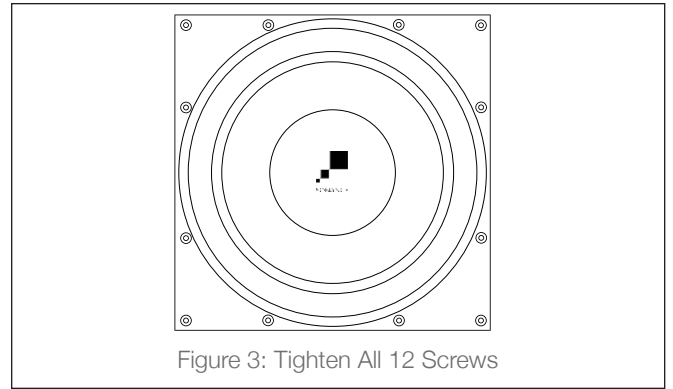

Figure 3: Tighten All 12 Screws

Installing the Grille and Frame

1. Attach the grille mounting frame to the enclosure using the twelve Phillips head screws (see Figure 4).

NOTE: SHORTER SCREWS ARE FOR SINGLE DRYWALL, LONGER SCREWS ARE FOR DOUBLE DRYWALL

2. Tighten all the screws evenly so the grille mounting frame is flush with the wall at all points around the perimeter.

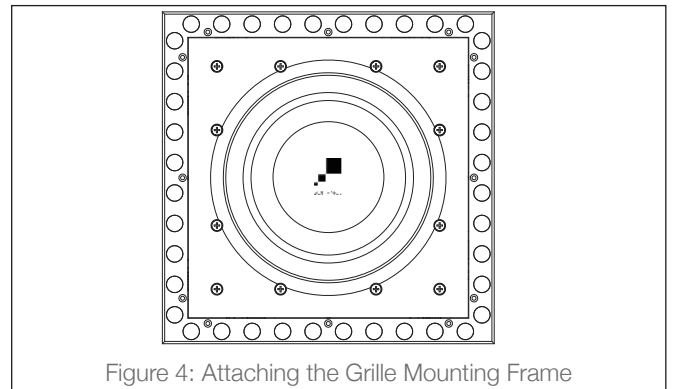

Figure 4: Attaching the Grille Mounting Frame

3. Install the grille on to the grille mounting frame. The powerful Neodymium magnets will attract the grille very quickly. Care should be taken to align the grille correctly before placing it close to the grille mounting frame (see Figure 5).

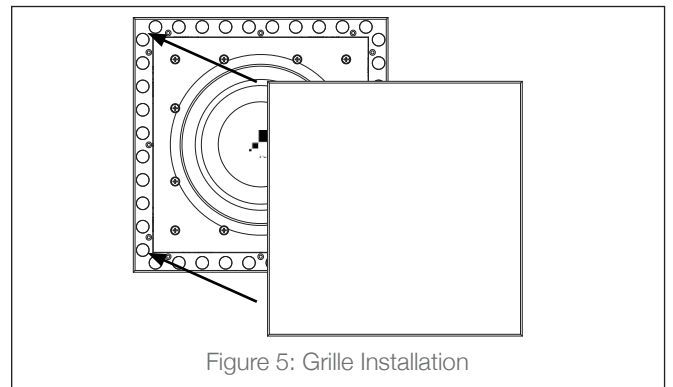

Figure 5: Grille Installation

Sonance warrants to the first end-user purchaser that this Sonance-brand product, when purchased from an authorized Sonance Dealer/Distributor, will be free from defective workmanship and materials for Five (5) Years from the date on the original sales receipt or invoice or other satisfactory proof of purchase. Sonance will at its option and expense during the warranty period, either repair the defect or replace the Product with a new or remanufactured Product or a reasonable equivalent.

©2017 Sonance. All rights reserved. Sonance is a registered trademark of Dana Innovations. Due to continuous product improvement, all features and specifications are subject to change without notice. For the latest Sonance product specification information visit our website: www.sonance.com

SONANCE • 991 Calle Amanecer • San Clemente, CA 92673 USA(949) 492-7777 • FAX: (949) 361-5151 • Technical Support: (949) 492-7777

33-7913 11.29.18